

# Type H9C Load Cell



## Short description



- Nickel plated alloy steel IP67 dual shear beam load cell
- High accuracy
- Suitable for truck and track scales and other heavy weighing devices
- Sealed construction



Test certificate no. D09-07.07  
Certificate no. 07-018A1

## Available models

Capacity	Accuracy	Full article description
5Klb	C3/C4	H9C-C3/C4-5K-9B
10Klb	C3/C4	H9C-C3/C4-10K-9B
20Klb	C3/C4	H9C-C3/C4-20K-9B
30Klb	C3	H9C-C3-30K-9B
40Klb	C3	H9C-C3-40K-9B
50Klb	C3	H9C-C3-50K-9B
60Klb	C3	H9C-C3-60K-9B
75Klb	C3	H9C-C3-75K-9B
100Klb	C3	H9C-C3-100K-9B
150Klb	C3	H9C-C3-150K-9B
200Klb	C3	H9C-C3-200K-9B
250Klb	C3	H9C-C3-250K-9B

Specifications and dimensions are subject to change without notice and do not constitute any liability whatsoever.

# Type H9C Load Cell

## Technical specifications H9C

Accuracy class		OIML R60 C3	OIML R60 C4
Output sensitivity ( = FS )	mV/V	3.0 ± 0.008	
Maximum capacity ( E <sub>max</sub> )	Klb	5, 10, 20, 30, 40, 50, 60, 75, 100, 150, 200, 250	5, 10, 20
Max. number of load cell intervals	n <sub>LC</sub>	3000	4000
Ratio of min. LC verification interval	Y = E <sub>max</sub> / v <sub>min</sub>	10000	15000
Combined Error	%FS	≤± 0.0230	≤± 0.0175
Minimum dead load	Of E <sub>max</sub>	0%	
Maximum side load	Of E <sub>max</sub>	100%	
Safe overload	Of E <sub>max</sub>	150 %	
Ultimate overload	Of E <sub>max</sub>	300 %	
Zero balance	Of FS	< ± 1.0 %	
Excitation, recommended voltage	V	5 ~ 12	
Excitation maximum	V	18	
Input resistance	Ω	700 ± 7	
Output resistance	Ω	700 ± 7	
Insulation resistance	MΩ	≥5000 ( at 50VDC )	
Compensated temperature	°C	-10 ~ +40	
Operating temperature	°C	-35 ~ +65	
Storage temperature	°C	-40 ~ +80	
Element material		Nickel plated alloy steel	
Ingress Protection (acc. to EN 60529)		IP67	
Deflection at E <sub>max</sub>	mm	5 Klb = 0.5, 10 Klb = 0.6, 20 Klb = 1.1, 30-50Klb = 0.5, 60 Klb = 0.6, 75-100 Klb = 0.5, 200-250Klb = 0.9	
ATEX classification (optional)		II3G Ex nA IIC T4 Gc	II3D Ex tc IIIC T73°C Dc
		II1G Ex ia II1C T4	II1D Ex iaD 20 T73°C

## Wiring

### Features:

Shielded, 4 conductor cable

Cable diameter for 5k – 20k: Ø5mm and for 30k – 250k: Ø8mm

Standard cable length: 9m

Shield not connected to element

### 4-wire diagram

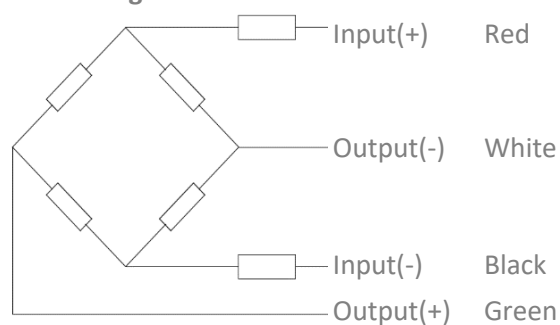

Specifications and dimensions are subject to change without notice and do not constitute any liability whatsoever.

# Type H9C Load Cell

Dimensions in mm

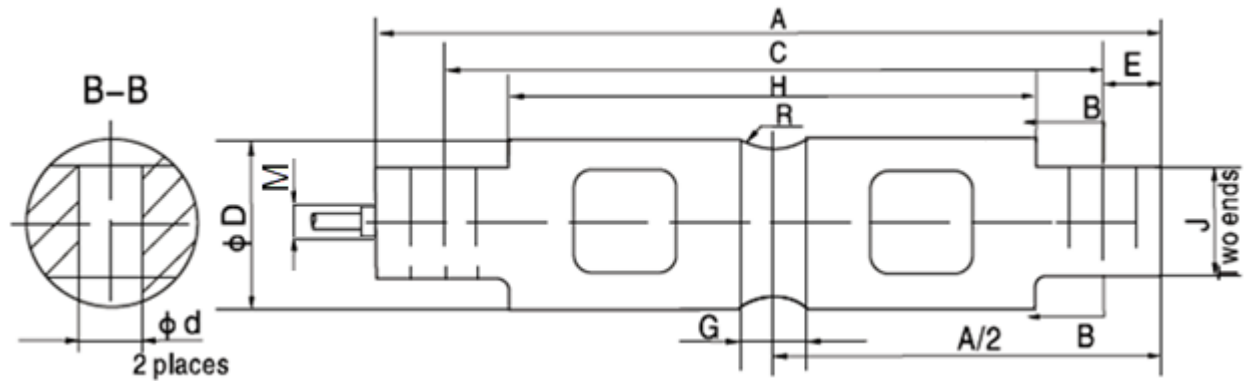

Dimension Capacity	A	C	H	G	ØD	J	Ød	R	E	M
5Klb, 10Klb	206.2	174.6	133.1	15.7	43.2	28.4	16.7	12.7	15.7	3/8-18 UNF-2B
15Klb, 20Klb	206.2	174.6	133.1	21.3	49.5	28.4	16.7	12.7	15.7	3/8-18 UNF-2B
30Klb-75Klb	260.4	215.9	165.1	25.4	76.2	60.2	26.9	25.4	22.4	3/8-18 UNF-2B
90Klb, 100Klb	285.8	241.3	190.2	31.0	88.9	63.5	26.9	38.1	22.4	3/8-18 UNF-2B
150Klb	285.8	241.3	190.2	31.0	99.1	71.1	26.9	38.1	22.4	3/8-18 UNF-2B
200Klb, 250Klb	408.9	330.3	254	31.7	136.6	116.8	39.6	50.8	39.4	3/8-18 UNF-2B

Specifications and dimensions are subject to change without notice and do not constitute any liability whatsoever.

# Type H9C Load Cell

## Available accessories

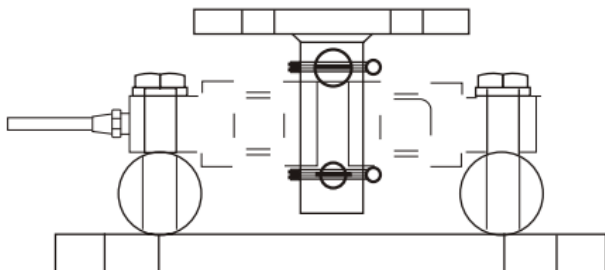
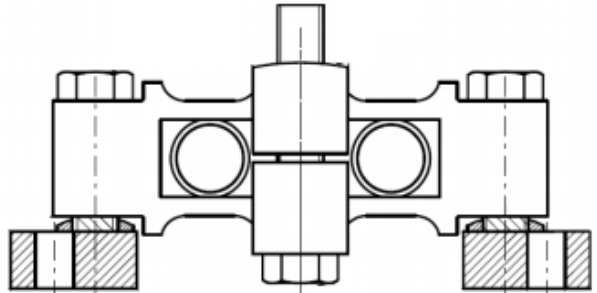
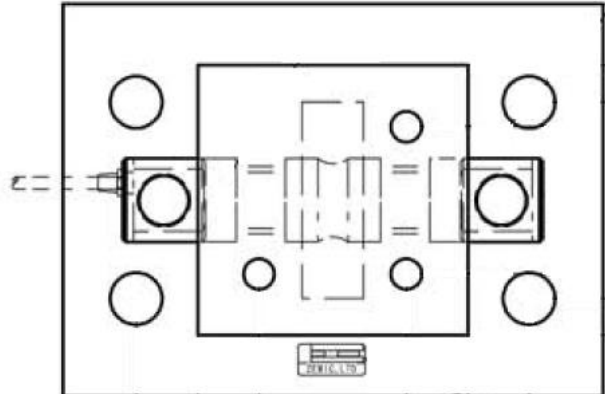
<p><b>HM-9-401-5-250Klb Mount</b></p> <ul style="list-style-type: none"><li>• Easy installation</li><li>• Compact construction</li><li>• Anti-reversal ability</li><li>• Alloy steel</li><li>• Using under heavy static or slight dynamic load</li></ul>	
<p><b>HM-9-405-30-75Klb Mount</b></p> <ul style="list-style-type: none"><li>• Alloy steel</li><li>• No horizontal movement</li></ul>	
<p><b>HM-9-409-5-20Klb</b></p> <ul style="list-style-type: none"><li>• Easy installation</li><li>• Compact construction</li><li>• Anti-reversal ability</li><li>• Alloy steel</li><li>• Using under heavy static or slight dynamic load</li></ul>	

Specifications and dimensions are subject to change without notice and do not constitute any liability whatsoever.